

VP,VN Commodore LPG installation utilising an LPG Memcal and Apexus Quick-kit. For vehicles fitted with automatic transmission only.

Description of the components and operation

LPG/Petrol changeover switch

The LPG change-over switch is mounted in the lower instrument panel to the left of the steering wheel, Apexus switch model PS101(b). The switch has illuminated indicators for "Petrol" and "LPG". When the switch is in the "LPG" position the vehicle is operating on Liquefied Petroleum Gas (LPG) Fig. 1.



Fig. 1 Apexus PS101(b) Gas/Petrol mode switch

Petrol operation

The vehicle will run on petrol when the switch is in the 'PETROL' position and the Yellow indicator is lit. In this mode the LPG system is turned 'OFF' and the vehicle functions in the same way as a vehicle not fitted with LPG, except that the engine management petrol control system will not operate the Lean Cruise Mode. 12 volts is applied to terminal C9 of the 'Engine Control Module' (ECM) from the LPG\PETROL changeover switch. The application of this voltage to the ECM causes it to operate the vehicle in petrol mode. The fuel gauge shows the amount of petrol in the petrol tank.

LPG operation

When the Green indicator is lit the switch is in the 'LPG' position and the engine management computer (ECM) is operational in the LPG mode enabling the vehicle to run on LPG. The original dashboard fuel gauge shows the amount of LPG in the LPG cylinder when operating in the LPG mode and the amount of petrol when operating on petrol Fig. 2. In the LPG mode the 12 volt signal wire to the ECM is removed and 12 volts is applied to the 'LPG MIXTURE CONTROL COMPUTER' and the LPG valves, via an electronic safety cutout. This enables the vehicle ECM to operate the LPG system and provides power to the 'LPG MIXTURE CONTROL

COMPUTER' to ensure closed loop control of fuel mixture.

Injector Pulse width

In all LPG operating modes, except engine cranking the petrol injector pulse width is set to zero. The ECM injects petrol during cranking to assist starting. The amount of petrol delivered during the start, crank interval is determined by the coolant temperature and the crank time Fig. 3. After starting no further petrol is delivered to the engine.

Petrol Fuel Pump

The petrol fuel pump relay operates the petrol pump for about two seconds when the ignition switch is first turned on and continues to operate during cranking Fig.4. During normal LPG operation the petrol pump is not running unless engaged by the ECM.

Memcal

The Memcals are installed/removed by disconnecting the battery from the vehicle, removing the top cover on the ECM module located in the left hand kick panel of the vehicle and then pulling outwards the two locking tabs retaining the Memcal in position. The LPG Memcal is then substituted for the Petrol Memcal in the polarised connector and the locking tabs and cover replaced Fig. 5 and Fig. 6.



Fig. 2 Dash board Fuel Gauge used for LPG and Petrol

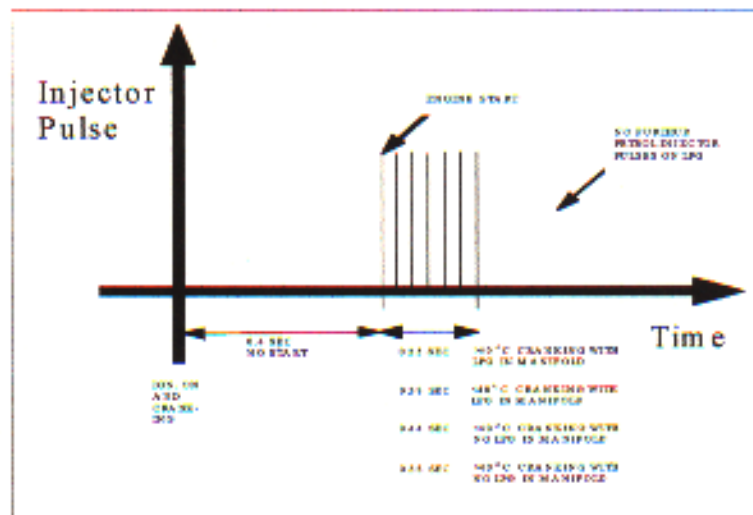

Fig. 3 Petrol Injector Pulses

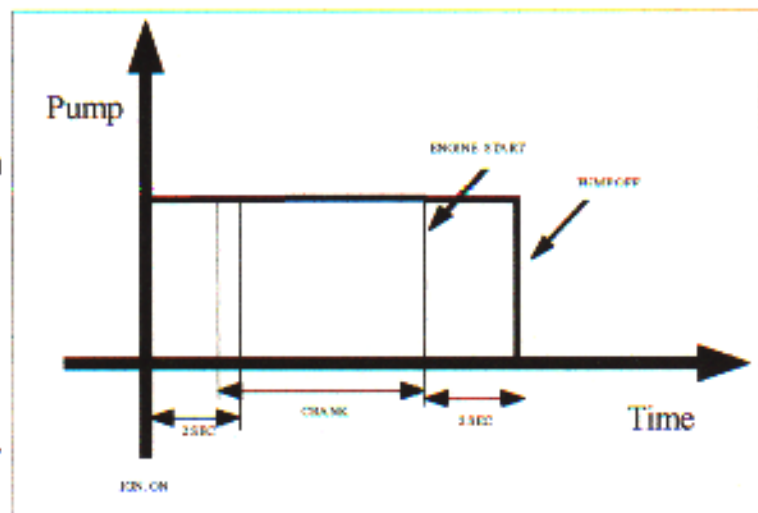

Fig. 4 Petrol Pump Operation

The PROM (Programmable Read Only Memory) contained within the LPG Memcal has been programmed so that the ECM can operate in one of two modes, either 'Petrol' or 'LPG'.

Which mode the ECM is operating in is determined by whether or not there is 12 volts on terminal C9 of the ECM.

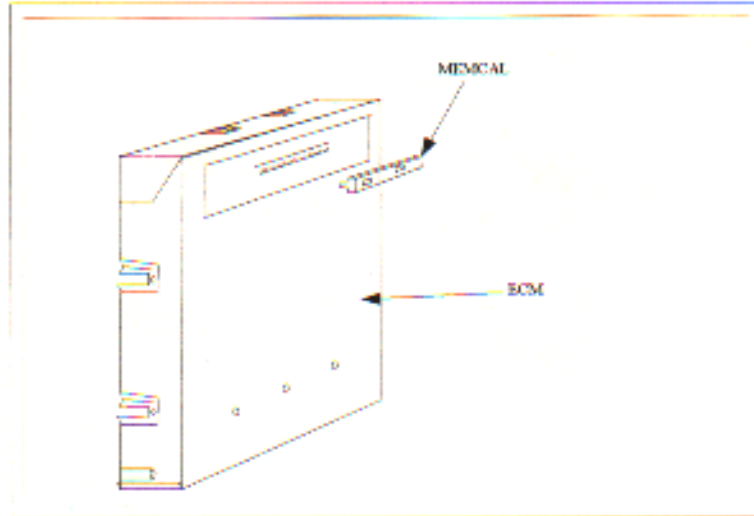

Fig. 5 Memcal Location Diagram

Installation

Determine the correct VP Memcal to install into the Engine Control Module (ECM). The LPG Memcal should have No BBMM9086

Mechanical Installation

Fit, tank, LPG(Liquefied Petroleum Gas) lines, converter, mixer, water lines, vapour line, vapour control valve, filler system, lock-offs and any other hardware required for the particular installation. The engine bay LPG lock-off (solenoid valve) and the vaporiser(converter) should be fitted close to the LHS(Left Hand Side) spring tower Fig. 8.

Electrical Installation

Preparation before fitting loom

Remove the LHS and RHS(Right Hand Side) kick panel revealing the ECM (Engine Control Module) on the LHS and wiring loom on the RHS(Right Hand Side). Remove the cover panel under the steering wheel and the glove-box. The ECM module is removed from its plastic carriage by releasing the clips and sliding upwards. Unplug the two connectors from the end of the ECM and remove from the vehicle.



Fig. 6 Fitting a Memcal

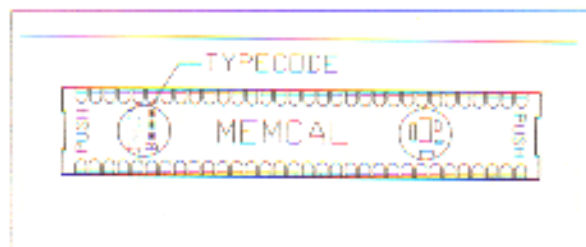

Fig. 7 Identifying Memcal Typecode

The ECM wiring loom has a sub-loom plug about 300mm from the ECM connectors, disconnect this plug Fig. 17. By pressing the three latches on the large firewall grommet located inside of the vehicle LHS release the grommet and pull the ECM loom into the engine bay. Using a sharp knife carefully slice the rubber grommet at the ends of the plastic clip and remove from the vehicle loom Fig. 9. Using the sharp knife remove enough rubber from the inside of the grommet to allow the LPG loom (engine bay section) and the mixture control valve wiring to fit without over expanding the grommet.

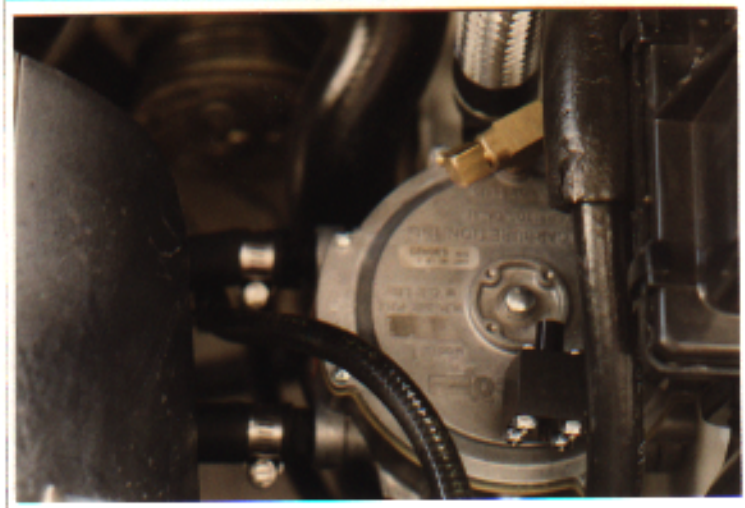

Fig. 8 Vapouriser

Loom installation engine bay

Fit a changeover relay into the spare location in the engine relay box on the support bar marked "HORN THEFT" and mark the location using the sticker provided "LPG (Petrol Pump Isolate)" Fig. 10.

If this location is not available fit the relay nearby and mark the relay with the sticker. Cut the Orange wire which goes to terminal 87a of the relay marked "F/PUMP" about 200mm from the relay. The Orange wire is from the oil pressure switch, this wire changes from Violet to Orange in the loom plug from the pressure switch. Bring the engine bay part of the LPG loom through the grommet hole opened in the preceding paragraphs. Lay the LPG loom



Fig. 9 Firewall Grommet Modification

around the engine bay with other vehicle wiring crossing the front of the vehicle by tucking it under the radiator sealing strips Fig. 12. Neatly feed the end of the LPG loom into the relay box and crimp the two Orange wires coming from the LPG loom about 300mm before the end onto the Orange wires from the fuel pump relay exposed above Fig. 11. The order of these wire is not important. Remove the cover from the front RHS relay box and unclip the relay bar from the body by releasing the two spring clips on the top surface. Clip the new relay socket found at the end of the Quick-kit loom onto a spare space on the relay bar and mark "FUEL

PUMP ISOLATION RELAY' with the sticker provided. If there is no spare space fix the relay to the side panel external to the relay box. Plug in the changeover relay. Tuck the wires neatly into place to allow the relay box to be refitted without jamming any wires Fig. 11. Next align the LPG engine loom section so that the Brown Tacho wire located in the vehicle wiring loom near the LHS spring tower Fig. 13 is near the single Brown wire from the LPG loom. Connect this wire from the LPG loom to the Brown Tacho wire, by baring the insulation on the Brown Tacho wire and soldering the connection. Bind this connection with amalgamating tape to insure no water ingress and to secure the joint. In this area plug the two 6.3 mm receptacles on the ends of the Brown and Pink wire to the Apexus CO100 electronic safety cut-out. Brown to the Pulse input and Pink to the +12V terminal Fig. 14. The Green wire coming from the safety cut-out plugs onto the piggyback terminal in the LPG loom which also plugs onto the LPG solenoid valve, a further Green wire goes to the vaporiser valve. It may be necessary to lengthen the vapouriser Green wire with the extension provided, depending on the position of the vapouriser. The Green wires in the loom are +12V power controlled by the Apexus electronic safety cut-out.

Loom installation vehicle cabin LHS

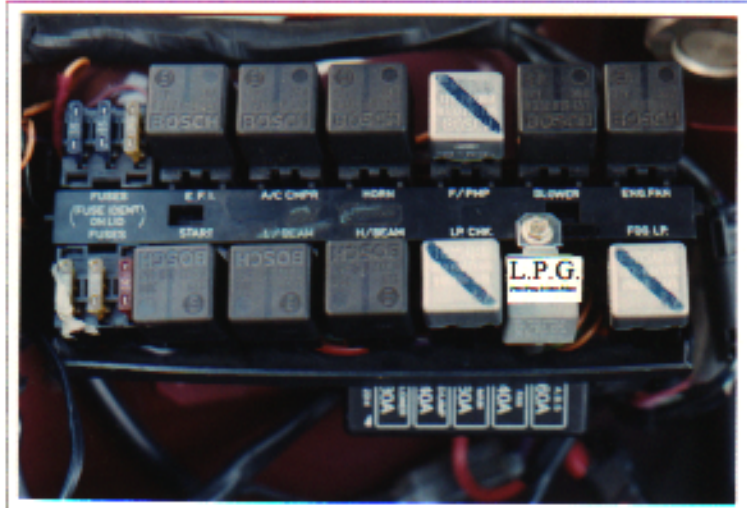

Fig. 10 Engine Bay Relay Box Showing Fuel Pump Isolation Relay Preferred Position.



Fig. 11 Relay Bar Removed From Mount Showing Isolation splice

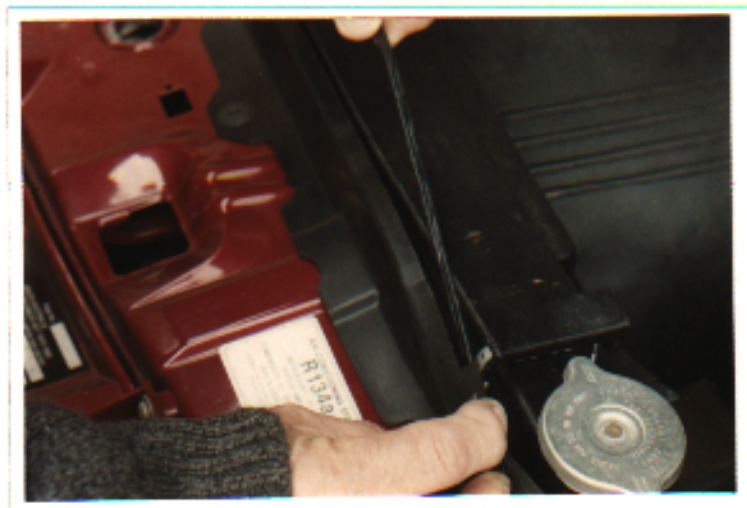

Fig. 12 Engine Bay Loom Being Fitted Under Radiator Trim

Connect the multiple wire from the LPG mixture control computer to the mixture control valve. Lay the LPG loom engine section and the mixture control valve multiple wire together with the original loom into the modified large rubber grommet and refit into the firewall. Reconnect the small sub loom plug on the inside of the car near the firewall grommet. Fit the fuel gauge changeover relay using a TEK screw into the LHS metal door pillar near the lower left of the ECM module plastic bracket, clear of the ECM connector positions. The 6mm earth ring terminal is fitted with the TEK screw holding this relay. This is the earth point for the LPG equipment including the mixture control computer, tank solenoid valve, relay coils, fuel switch lamps and tank sender.

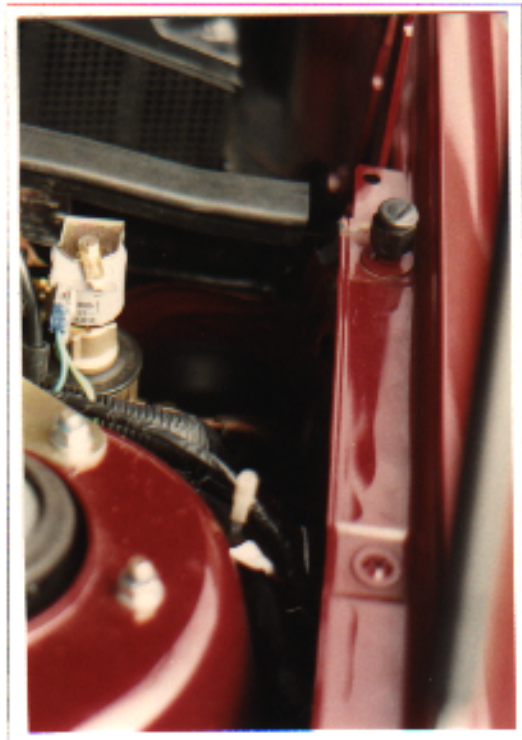

Fig. 13 Tacho Wire Pickup Point

Fitting mode switch to dashboard

Fit the fuel mode switch in the lower instrument panel located to the left of the steering wheel in the section above the plastic clip. This switch is fitted by carefully drilling a hole in the blank space and filing the shape to fit the switch provided (horizontal panel switch with indicator lamps for LPG and Petrol).

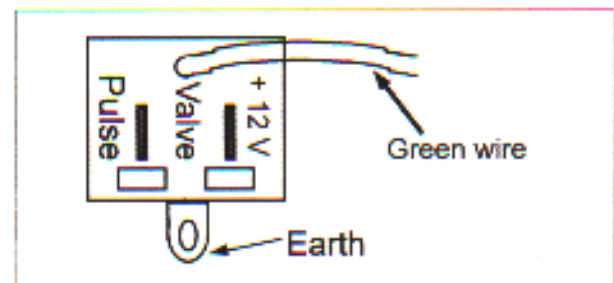

Fig. 14 Apexus CO100 Safety Cutout Terminals

Loom installation vehicle cabin RHS

Pass the fuel mode switch section of the LPG loom under the centre console to the RHS of the vehicle. Fit the four 6.3mm receptacles to the terminals on the fuel mode switch. Red to +12V, Pink to the LPG terminal, Yellow to the Petrol terminal and Black to the earth terminal. The Red wire is fused by the 5 Amp fuse located in the loom about



Fig. 15 Fuel Gauge Changeover Relay and Earth Point

200mm from the fuel mode switch wires Fig. 18. Arrange the placement of the fuse so it is close to the vehicle fuses and tie the loom in place using one or two cable ties. The remaining two wires in this section of the LPG loom on the RHS of the vehicle are connected to the wire coming from the Petrol sender and located in the RHS kick panel. The wire from the petrol sender is light Tan and can be found near the centre in the 16 pin two row White connector coming from the rear of the vehicle. Cut this wire and crimp

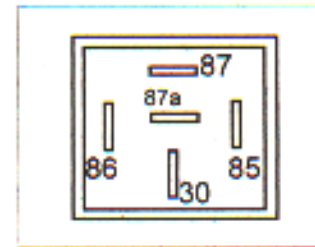

Fig. 16 Changeover Relay Terminals

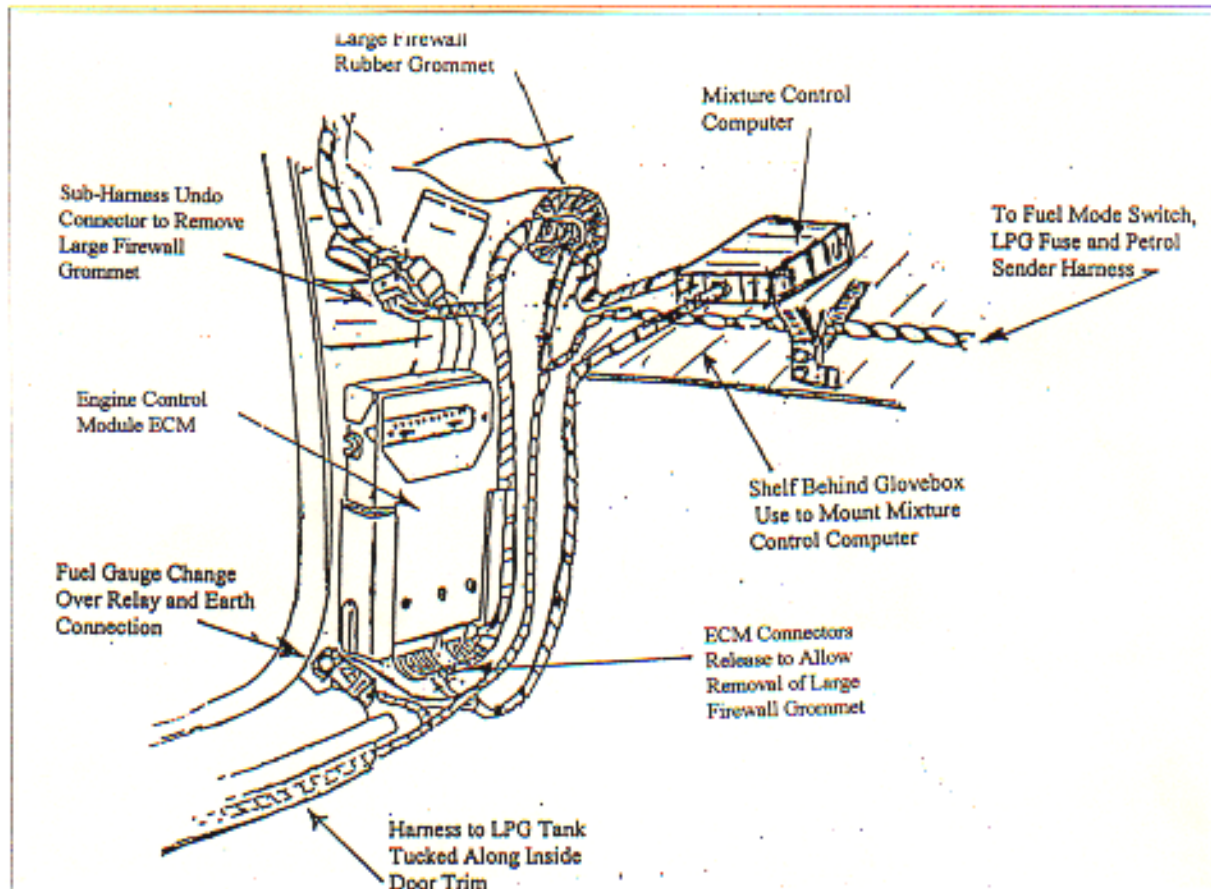

Fig. 17 Loom Layout in Area Around LHS Door Pillar.

onto the ends the Violet and Grey wires remaining in this section of the LPG loom. The Grey wire is crimped to the light Tan wire from the rear of the car and the Violet wire is crimped to the light Tan wire coming from the dashboard end Fig. 19.

Installation of the ECM wiring

On the LHS of the vehicle connect the Red wire from the LPG loom to the Pink wire coming from cavity A6 of the ECM connector by stripping about 20mm of insulation from the Pink wire about 200 mm from the plug without breaking the internal copper strands of the Pink wire. Fold the Pink wire double at the bared position and fit a mating connector to the Red wire from the LPG harness.. The Yellow wire in the

LPG loom is already fitted with a terminal which is plugged into empty cavity C9 of the ECM connector Fig. 20. The ECM connectors use a letter to designate each of the sides of the connector. A and B are the two sides of the smaller ECM connector and C and D the two sides of the larger connector. A plastic retainer clip is removed to allow terminal insertion.

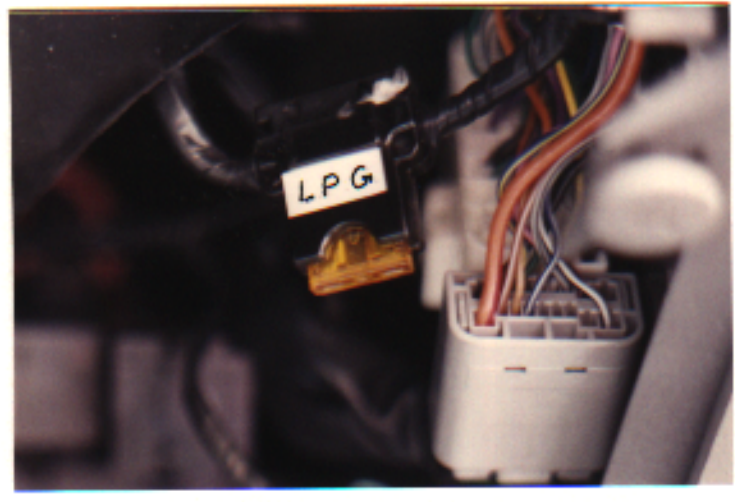

Fig. 18 Fuse Panel under Steering Wheel with in Loom LPG Fuse

The Pink wire from the LPG loom is crimped to the +12V line going to the LPG Mixture Control Computer which is mounted on the shelf behind the glove box using 2double sided tape, or screwed into place. A Black earth wire is also provided from the LPG loom for the LPG Mixture Control Computer, crimp this wire to the earth wire from that computer. A Brown wire is provided for Mixture Control Computers which require a Tacho input, if this wire is not required tape along the LPG loom. Use the same fold and crimp method outlined above to join the mixture control computer oxygen sensor input and throttle position sensor input to the ECM. These two wires are not in the LPG loom and are wired directly from the LPG mixture control computer to the wires entering cavities C13 and D7 on the ECM. Cavity C13 contains the Blue wire coming from the wiper of the vehicles (TPS) Throttle Position Sensor and cavity D7 contains the Violet wire coming from the vehicles oxygen sensor Fig. 17.



Fig. 19 RHS Door Pillar Showing Fuel Gauge Splice and LPG Fuse.

Loom installation rear of vehicle

The remainder of the LPG loom runs to the rear of the vehicle. Tuck the loom under the LHS front and rear door kick trims.

Feed the loom around the back seat and into the boot through

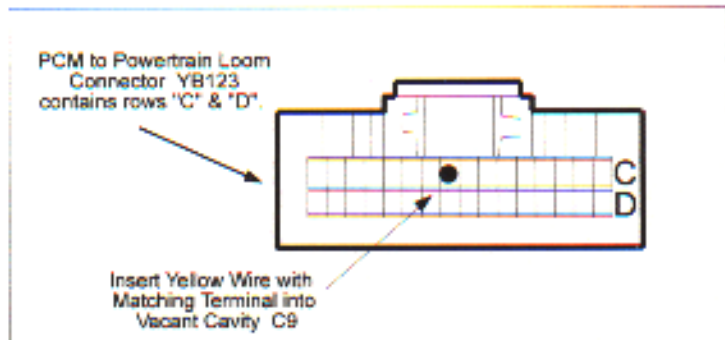

Fig. 20 PCM Connector Showing Cavity C9

the centre fold seat upright. This can be done without removing the seat. When correctly in place the wiring should be completely hidden from view. Drill a 10mm hole in the vehicle floor near the vent pipe outlet flange, insert the end of the loom through the 10mm hole and locate the grommet already fitted to the loom into the hole. Now take the remainder of the wiring into the subcompartment via the vent tube. Connect the two 6.3mm receptacles at the end of the LPG loom to the 282-40 Ohm tank sender in the LPG tank. **Check the correct sender type (282-40 Ohm) is installed in the LPG tank as the wrong type may damage the vehicle fuel gauge.** The sender is not polarity sensitive so either terminal may be connected to the black or white wire. Feed the two tank solenoid valve wires through the vent tube and grommet and connect to the green and black wires in the LPG loom, the Black wire goes to earth and the green wire goes to the electronic safety cut-out Fig. 21. If necessary ensure the grommet is sealed with a small amount of silicon rubber sealant.

Memcal installation

Install the LPG Memcal by opening the cover on the vehicle ECM and pressing the clip at end of the Memcal unit. Replace the petrol Memcal with the correct model LPG Memcal and replace the cover Figs. 5, 6 & 7. Re-install the ECM into the vehicle and reconnect the ECM connectors. Reconnect the battery.

System check and commission

Check system operation. Following normal procedure check safety cut-out operation at each valve. The fuel gauge must read the LPG sender when switched to LPG and read the petrol sender during operation on petrol. The petrol pump should be off during LPG operation except for a few seconds during petrol start. During operation on petrol the petrol pump isolation relay must be closed connecting the two orange wires. For operation on LPG the isolation relay contacts are open.

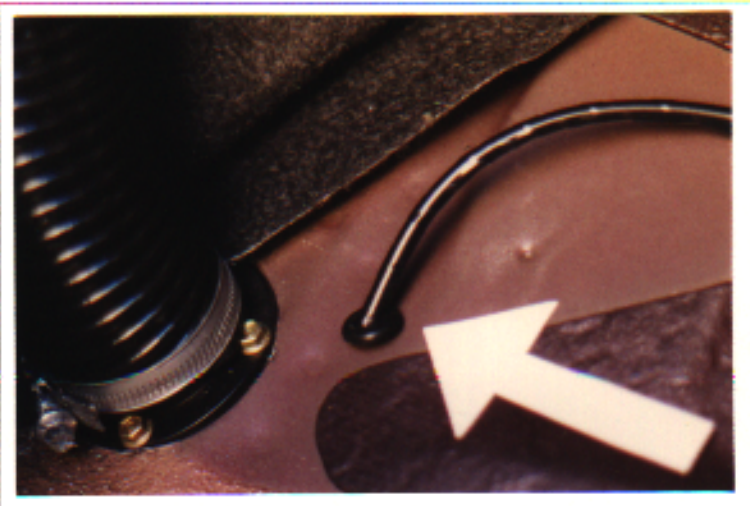

Fig. 21 Rubber Grommet Entry to Sub-Compartment.

If the vehicle fails to operate on petrol check to ensure that the yellow wire is connected to the correct cavity on the ECM connector and that there is +12V on this terminal when switched to petrol.

When you are satisfied with the vehicle operation and tuning of the mixture control

computer and manual vapour valve if fitted, ensure that all wiring is neatly and securely located with cable ties to avoid rattles and squeaks, replace the kick panels on the LHS and RHS of the vehicle. Replace the glove-box and lower instrument panel. Place the sheet with the LPG layout diagram and wiring diagram in the glovebox for future maintenance.

Optional installation for additional LPG gauge

Where a customer requests a LPG gauge to be fitted in addition to the petrol gauge the following connections allow for such an installation. The gauge changeover relay is not fitted. At the changeover relay site it is necessary to connect the black wire terminated by a ring terminal to earth. A TEK screw in the same place as recommended to hold the relay when fitted, is a suitable way of making this earth connection. The White wire and the Violet wire which would normally go to the changer over relay are connected together using the blade to blade link provided in the Apexus kit. The remaining Grey, Pink and Black wires which would normally be connected to the changeover relay are taped back along the harness. On the right hand side of the cabin it is not necessary to remove right hand kick panel as for the standard installation. The Violet wire in the LPG harness on the RHS of the vehicle now comes from the LPG sender (**a 0 - 90 Ohm type must now be fitted instead of the 282-40 Ohm type which only drives the original dashboard fuel gauge and the 0 - 90 Ohm sender must be separately earth to the tank**). Connect the Violet wire to the sender terminal of the gauge to be used. The Grey should be taped along the loom as it is no longer required. The Apexus PG101b switch and gauge combination makes a neat, ergonomic, easily installed setup which has annunciators for LPG and Petrol as well as a self dimming feature for comfortable night viewing.

VN,VP Commodore LPG Electrical Layout Diagram

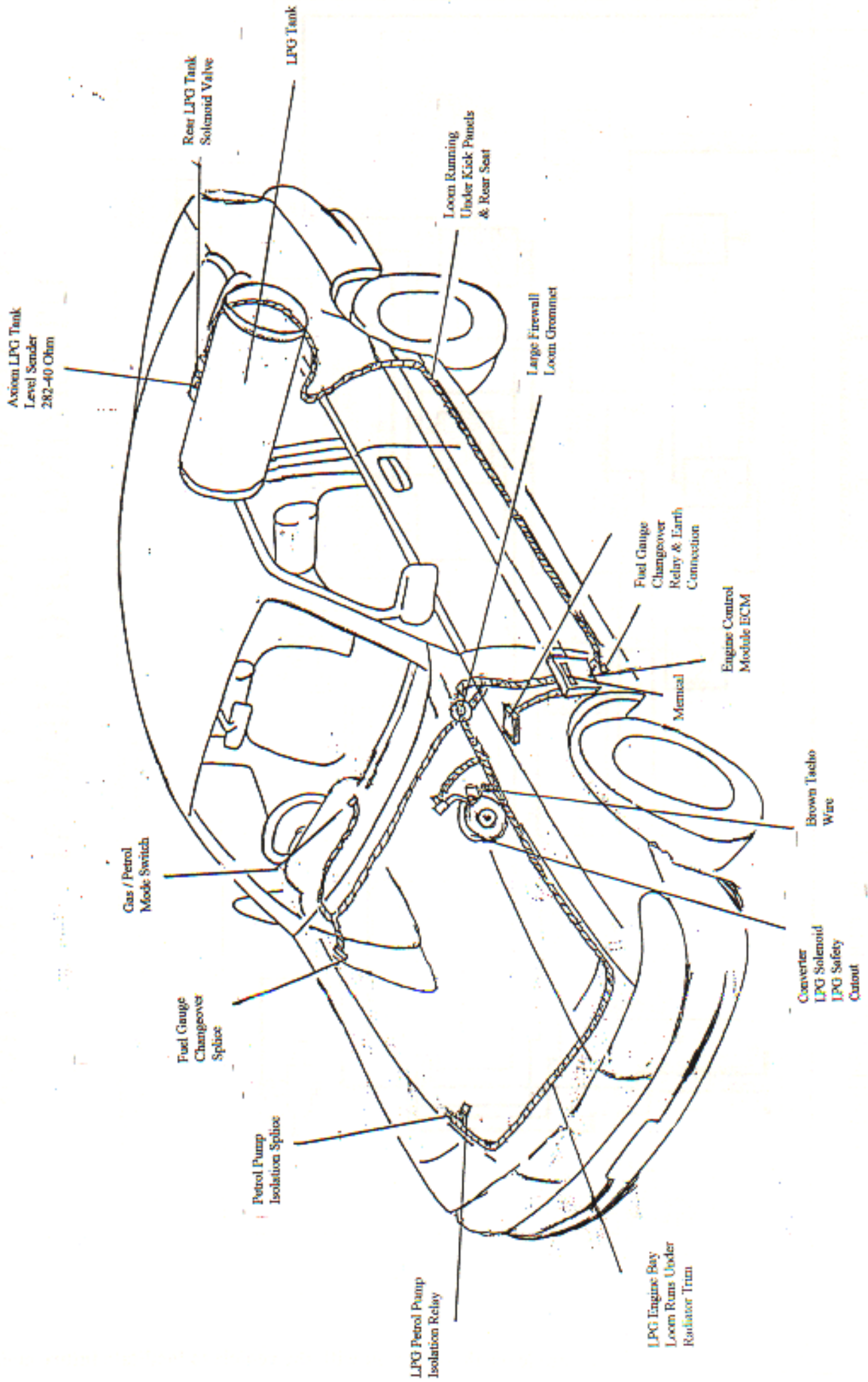

Please leave this diagram with the vehicle to facilitate future maintenance

